

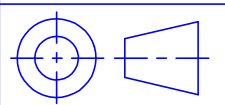

Unless otherwise specified dimensions are in millimetres. Tolerances are: XXX (0 PLS) ± 0.5 MM XX.X (1 PLS) ± 0.1 MM X.XX (2 PLS) ± 0.03 MM .XXX (3 PLS) ± 0.007 MM UNLESS OTHERWISE NOTED ANGLE TOLERANCE $\pm 0^{\circ}30'$, UNLESS NOTED Sheet Name: ISO_VIEWS	Name	Date	SIZE	 UNIVERSITY OF LIMERICK OLLSCOIL LUIMNIGH	
	Drawn Sara Mikolajczyk	21/03/2024	A4		
	Checked			Title:	
	DO NOT SCALE DRAWING			STIRLING ENGINE PROJECT	
 THIRD ANGLE PROJECTION			DWG. NO.	Material:	Weight:
			REV.	Scale: 1:2	Sheet 1 of 18

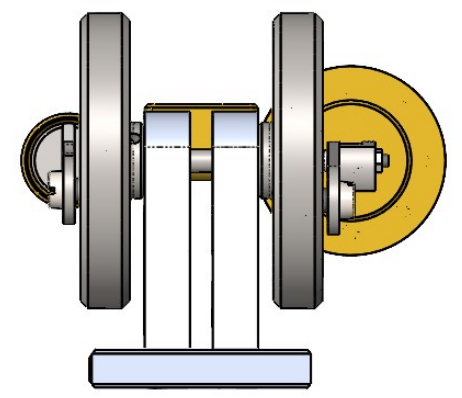

Unless otherwise specified dimensions are in millimetres. Tolerances are: XXX (0 PLS) ±0.5 MM XX.X (1 PLS) ±0.1 MM X.XX (2 PLS) ±0.03 MM .XXX (3 PLS) ±0.007 MM UNLESS OTHERWISE NOTED ANGLE TOLERANCE ±0°30', UNLESS NOTED Sheet Name: ASSY_ORTHO	Name	Date	SIZE	 UNIVERSITY OF LIMERICK OLLSCOIL LUIMNIGH
	Drawn Sara Mikolajczyk	21/03/2024	A4	
	Checked		Title:	
	DO NOT SCALE DRAWING		STIRLING ENGINE PROJECT	
		DWG. NO.	Material:	Weight:
		REV.	Scale: 1:2	Sheet 2 of 18

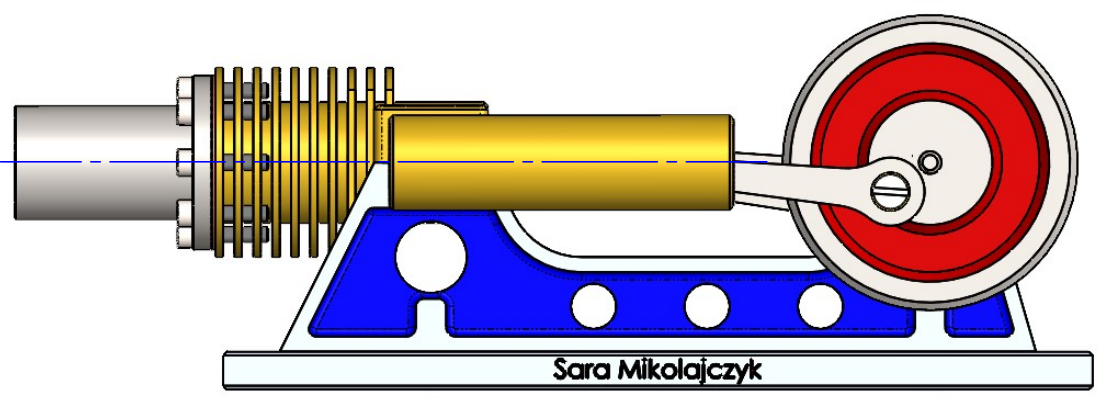
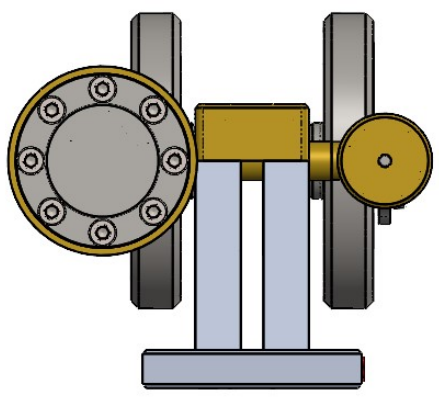
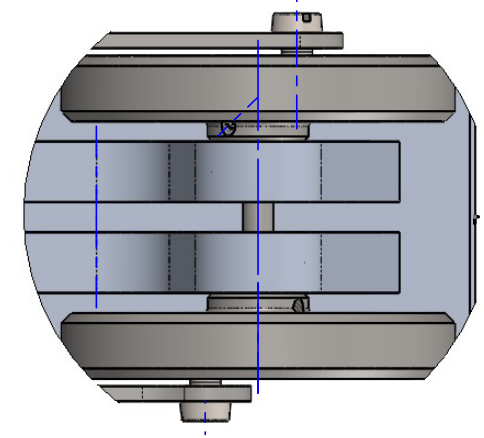
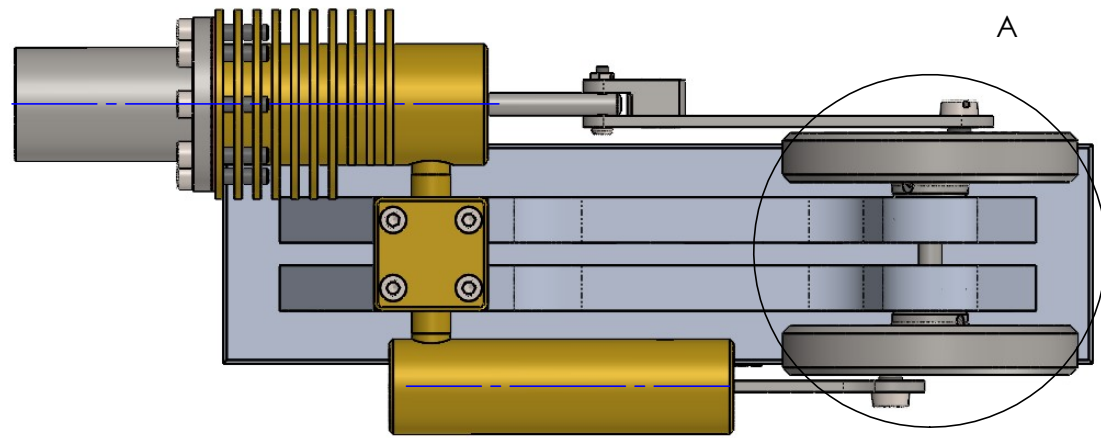

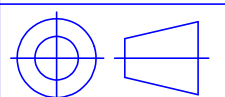
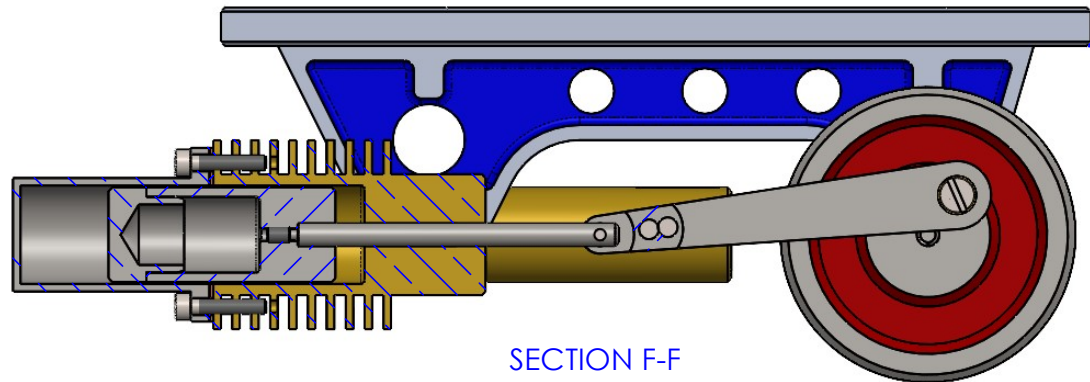
SECTION F-F

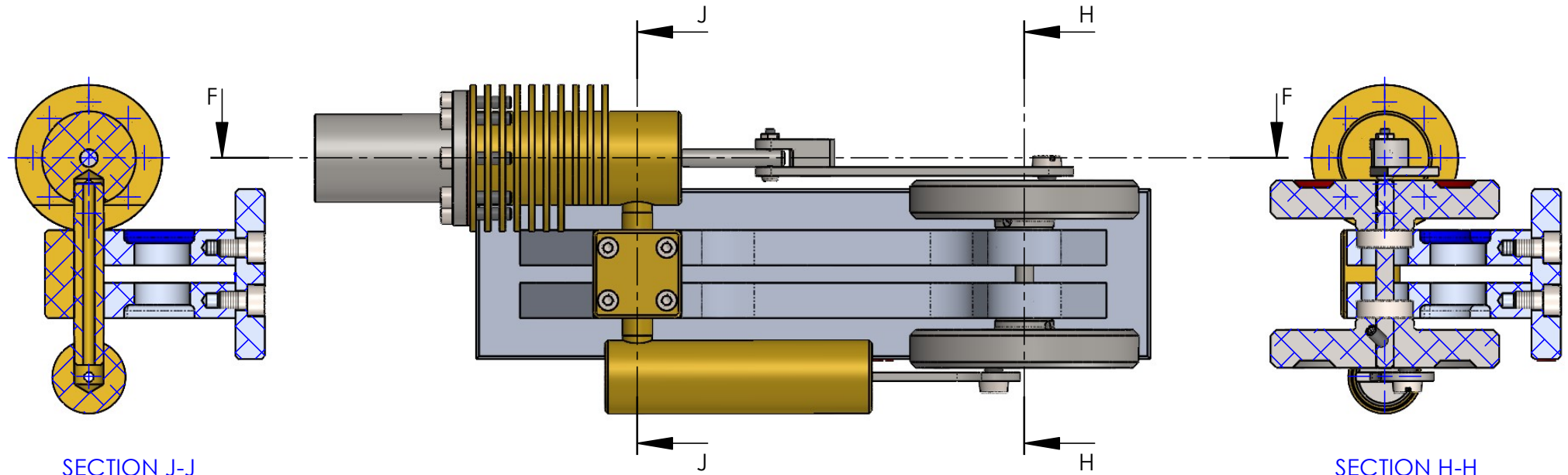

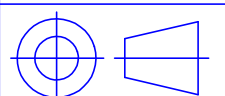

SECTION J-J

SECTION H-H

Unless otherwise specified dimensions are in millimetres. Tolerances are: .XXX (0 PLS) ±0.5 MM XX.X (1 PLS) ±0.1 MM X.XX (2 PLS) ±0.03 MM .XXX (3 PLS) ±0.007 MM UNLESS OTHERWISE NOTED ANGLE TOLERANCE ±0°30', UNLESS NOTED Sheet Name: ASSY SECT VIEWS	Name	Date	SIZE	 UNIVERSITY OF LIMERICK OLLSCOIL LUIMNIGH
	Drawn Sara Mikołajczyk	21/03/2024	A4	
	Checked		Title:	
	DO NOT SCALE DRAWING		STIRLING ENGINE PROJECT	
 THIRD ANGLE PROJECTION		DWG. NO.	Material:	Weight:
		REV.	Scale: 1:2	Sheet 3 of 18

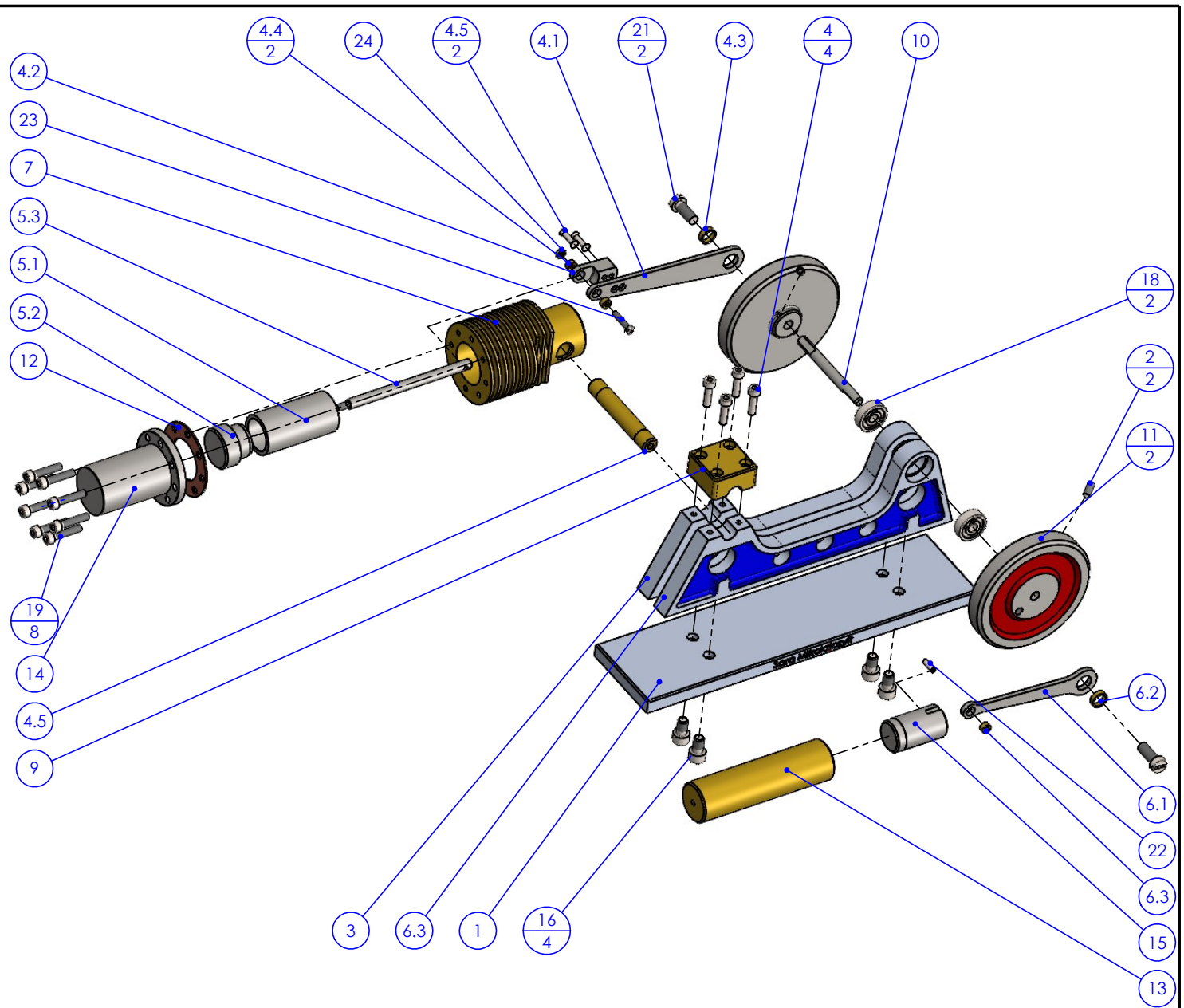
ITEM NO.	PART NUMBER	Material	QTY.
1	BASE PLATE	1060 Alloy	1
6.3	LEFT SIDE FRAME	1060 Alloy	1
3	RIGHT SIDE FRAME	1060 Alloy	1
4	DISPLACER CON-ROD ASSEMBLY		1
4.1	DISPLACER CON-ROD	Plain Carbon Steel	1
4.2	CON-ROD CLAMP	Plain Carbon Steel	1
4.3	BIG END BUSH	Brass	1
4.4	SMALL END BUSH	Brass	2
4.5	3 X 16 COUNTERSUNK RIVEL B - 661		2
5.1	DISPLACEMENT PISTOL BODY	Plain Carbon Steel	1
5.2	DISPLACEMENT PISTON CAP	Plain Carbon Steel	1
5.3	DISPLACEMENT PISTON SHAFT	Plain Carbon Steel	1
6	POWER CON-ROD ASSEMBLY		1
6.1	POWER CON-ROD	Plain Carbon Steel	1
6.2	BIG END BUSH	Brass	1
6.3	SMALL END BUSH	Brass	1
7	COLD CYLINDER	Brass	1
4.5	CROSS CYLINDER SUPPORT PIPE	Brass	1
9	CROSS CYLINDER SUPPORT	Brass	1
10	FLYWHEEL SHAFT	Plain Carbon Steel	1
11	FLYWHEEL	Plain Carbon Steel	2
12	GASKET	Copper	1
13	POWER CYLINDER	Brass	1
14	HOT CYLINDER	Plain Carbon Steel	1
15	POWER PISTON	Plain Carbon Steel	1
16	SOCKET HEAD CAP M6X10		4
4	BS EN ISO 4762 M4 x 16 - 16N		4
18	INSTRUMENT PRECISION BALL BEARING 20619		2
19	BS EN ISO 4762 M4 x 20 - 20C		8
2	M4 X 10 SOCKET GRUB SCREW CONE POINT		2
21	M6 X 16 SLOTTED CHEESE HEAD SCREW		2
22	M3 X 10 PARALLEL PIN		1
23	M3 X 16 SLOTTED PAN HEAD SCREW		1
24	M3 HEXAGONAL THIN NUT		1



Unless otherwise specified dimensions are in millimetres. Tolerances are: .XXX (0 PLS) ±0.5 MM .XX.X (1 PLS) ±0.1 MM .X.XX (2 PLS) ±0.03 MM .XXX (3 PLS) ±0.007 MM UNLESS OTHERWISE NOTED ANGLE TOLERANCE ±0°30' UNLESS NOTED Sheet Name:	Name	Date	SIZE	 UNIVERSITY OF LIMERICK OLLScoil Limerick
	Drawn Sara Mikolajczyk	21/03/2024	A3	
	Checked	DO NOT SCALE DRAWING		Title:
	EXPLODED VIEW	 THIRD ANGLE PROJECTION		STIRLING ENGINE PROJECT
DWG. NO.	Material:	Weight: 2777.72g		
REV.	Scale: 1:2.5	Sheet 4 of 18		

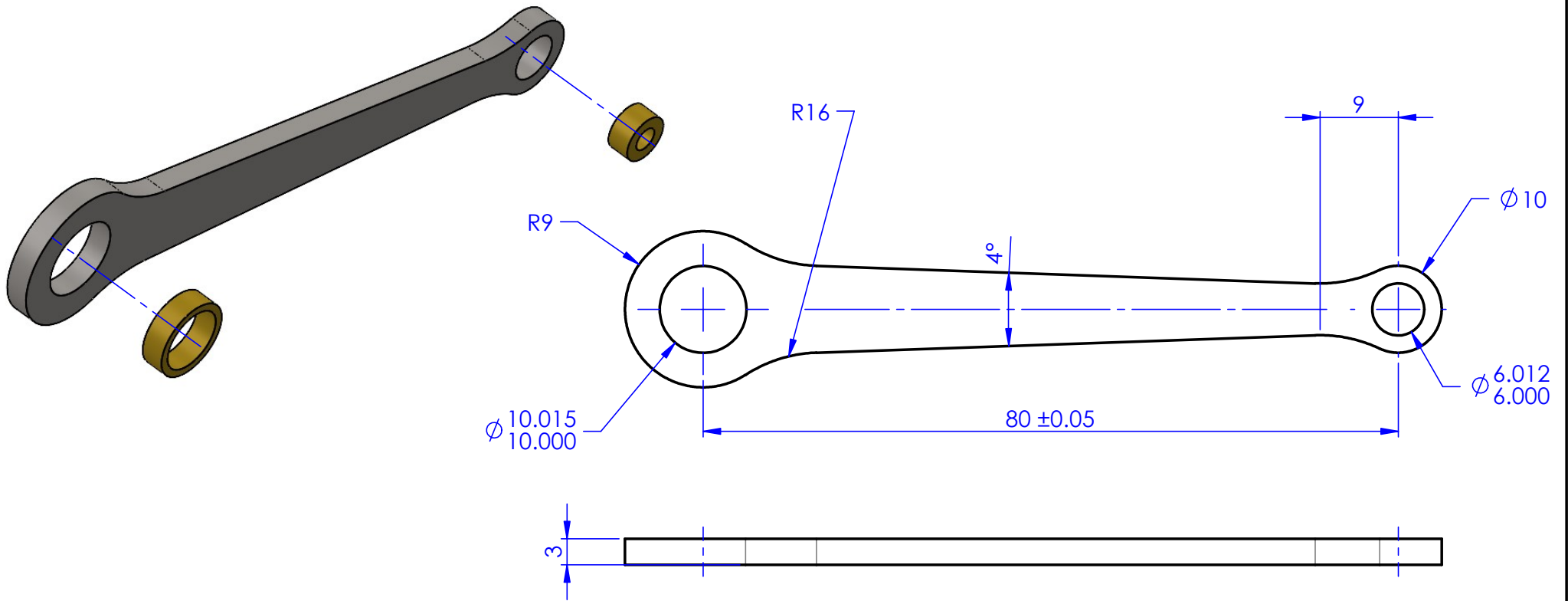

POWER CON-ROD - MATERIAL: PLAIN CARBON STEEL

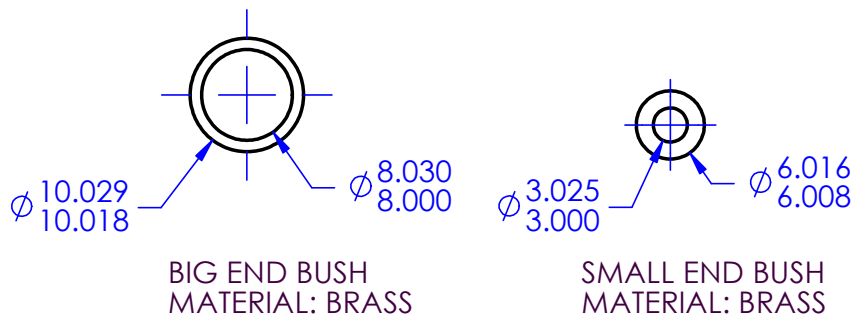

Unless otherwise specified dimensions are in millimetres. Tolerances are: .XXX (0 PLS) ±0.5 MM XX.X (1 PLS) ±0.1 MM X.XX (2 PLS) ±0.03 MM .XXX (3 PLS) ±0.007 MM UNLESS OTHERWISE NOTED ANGLE TOLERANCE ±0°30', UNLESS NOTED Sheet Name: POWER CON-ROD ASSY	Name	Date	SIZE	
	Drawn Sara Mikołajczyk	21/03/2024	A4	
	Checked		Title:	
	DO NOT SCALE DRAWING			POWER CON-ROD ASSEMBLY
		DWG. NO.	Material:	Weight:
		REV.	Scale: 1.5:1	Sheet 5 of 18

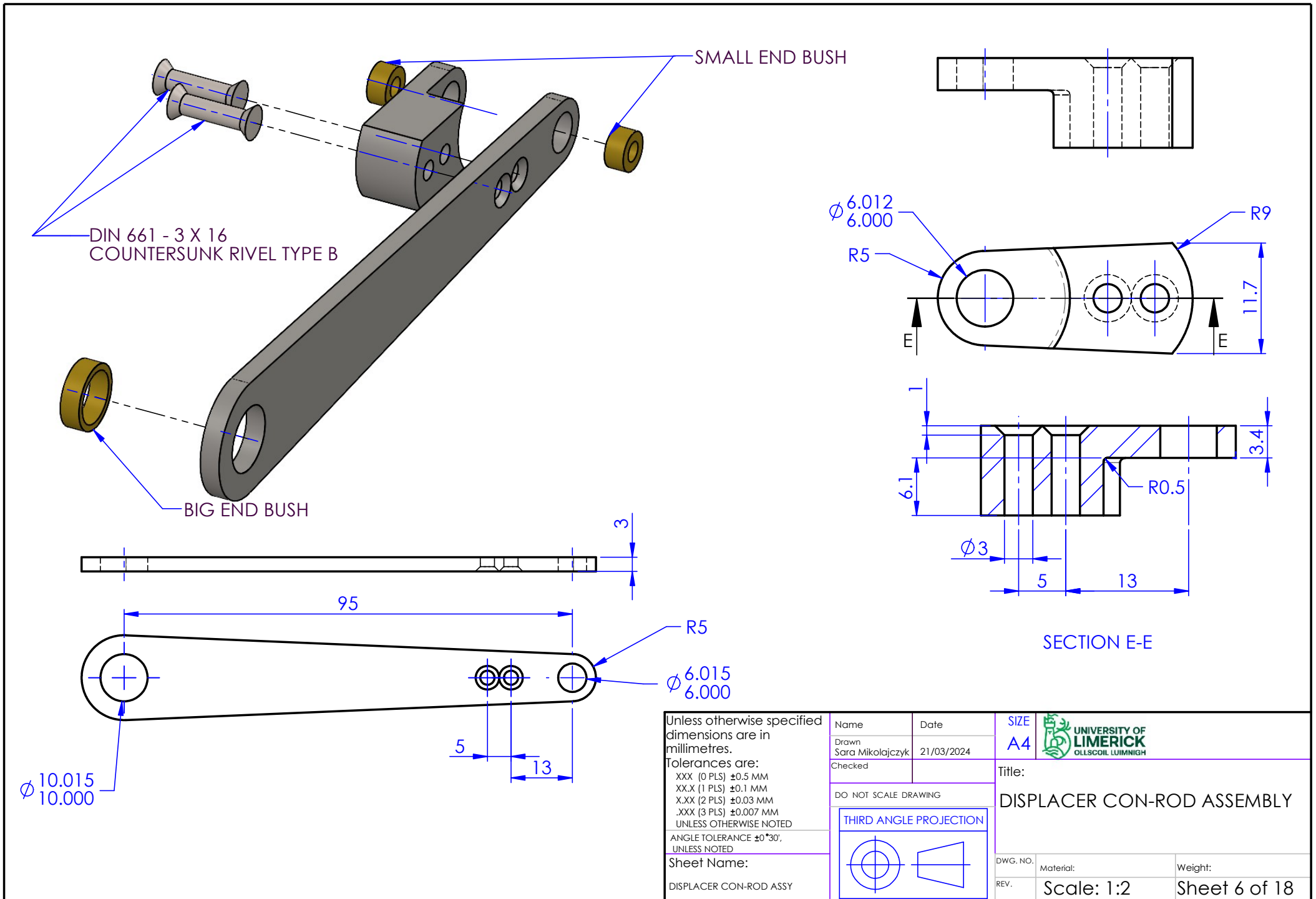

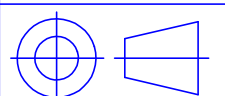
Unless otherwise specified dimensions are in millimetres. Tolerances are: XXX (0 PLS) ±0.5 MM XX.X (1 PLS) ±0.1 MM X.XX (2 PLS) ±0.03 MM .XXX (3 PLS) ±0.007 MM UNLESS OTHERWISE NOTED ANGLE TOLERANCE ±0°30', UNLESS NOTED Sheet Name: DISPLACER CON-ROD ASSY	Name	Date	SIZE	 UNIVERSITY OF LIMERICK OLLSCOIL LUIMNIGH
	Drawn Sara Mikołajczyk	21/03/2024	A4	
	Checked		Title: DISPLACER CON-ROD ASSEMBLY	
	DO NOT SCALE DRAWING		DWG. NO.	
	THIRD ANGLE PROJECTION		Material:	
			Weight:	
	REV.	Scale: 1:2	Sheet 6 of 18	

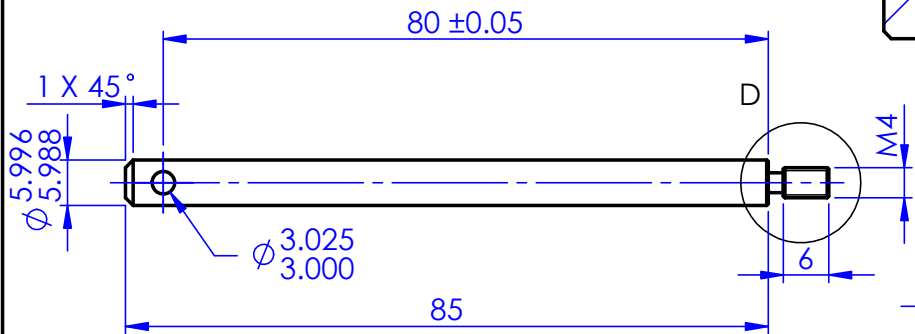
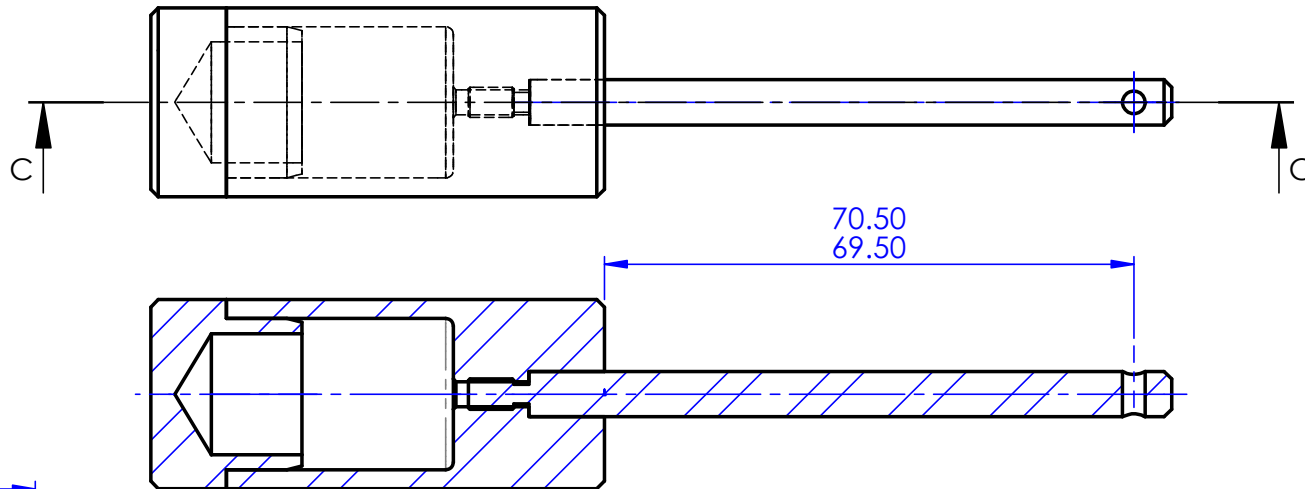
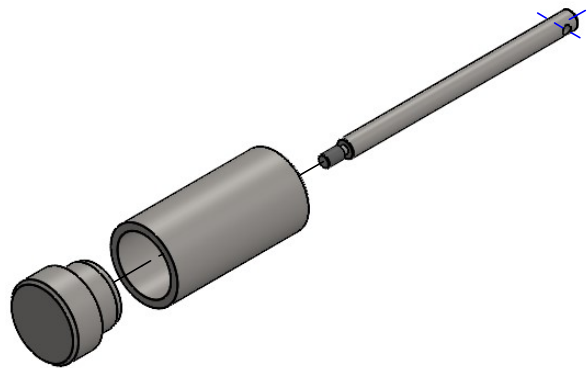

DISPLACEMENT PISTON SHAFT - MATERIAL: PLAIN CARBON STEEL

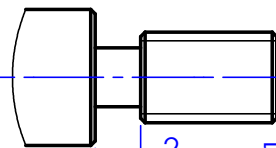

DETAIL D
SCALE 3 : 1

SECTION C-C
SCALE 1 : 1

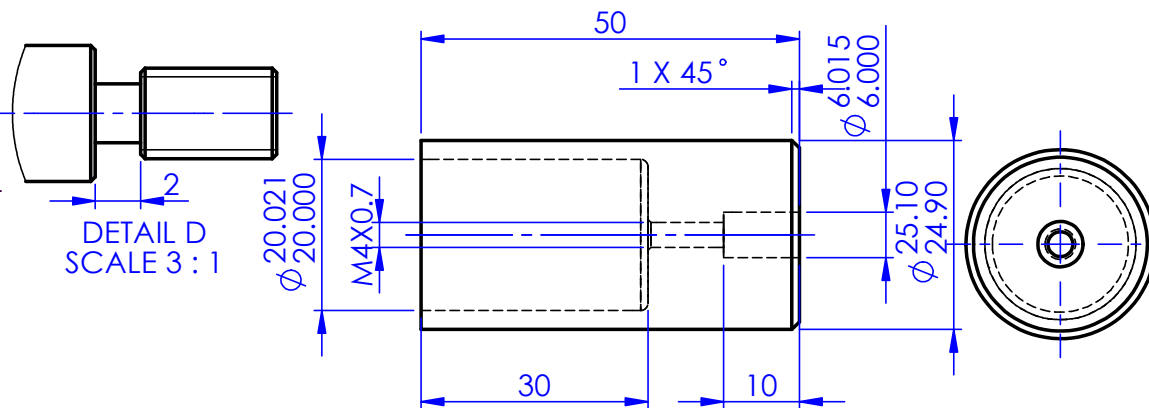

DISPLACEMENT PISTON BODY - MATERIAL: PLAIN CARBON STEEL

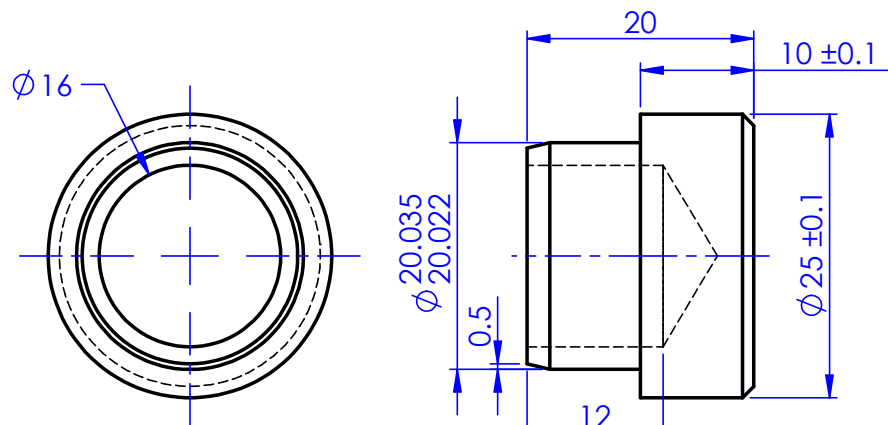

DISPLACEMENT PISTON CAP - MATERIAL: PLAIN CARBON STEEL

Unless otherwise specified dimensions are in millimetres. Tolerances are: .XXX (0 PLS) ±0.5 MM XX.X (1 PLS) ±0.1 MM X.XX (2 PLS) ±0.03 MM .XXX (3 PLS) ±0.007 MM UNLESS OTHERWISE NOTED ANGLE TOLERANCE ±0°30', UNLESS NOTED Sheet Name: DISPLACER PISTON ASSY	Name	Date	SIZE	UNIVERSITY OF LIMERICK OLLSCOIL LUIMNIGH
	Drawn Sara Mikołajczyk	21/03/2024	A4	
	Checked	DO NOT SCALE DRAWING		Title:
	THIRD ANGLE PROJECTION			DISPLACER PISTON ASSEMBLY
DWG. NO.	Material:	Weight:		
REV.	Scale: 1:1	Sheet 7 of 18		

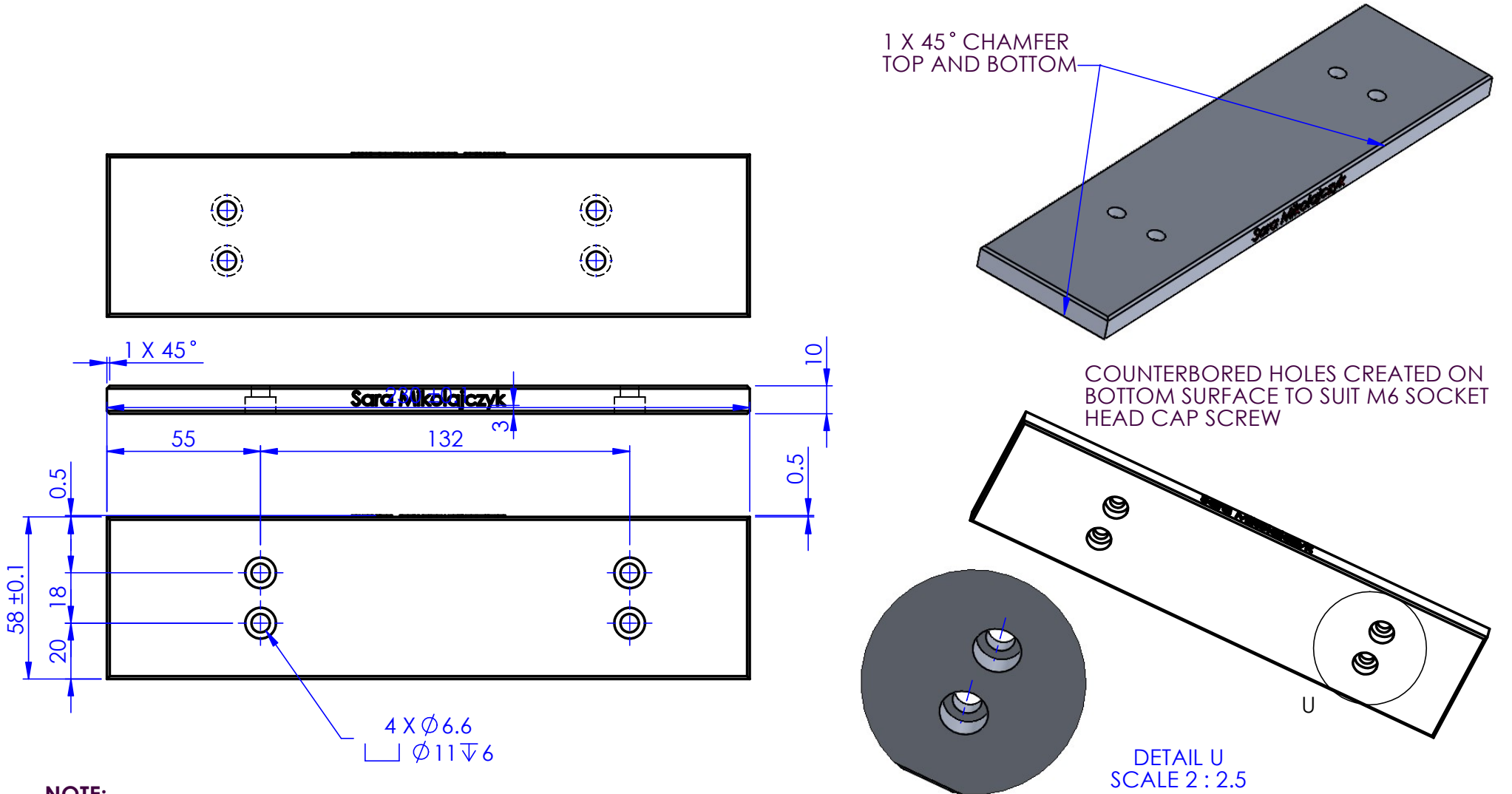

NOTE:
 ADD YOUR NAME **CENTRED** ON THE FRONT FACE IN **5MM** HIGH **RED** LETTERING WITH A PROTRUSION OF **0.5MM** AND **3MM** ABOVE THE BOTTOM SURFACE AS SHOWN ABOVE.

Unless otherwise specified dimensions are in millimetres. Tolerances are: XXX (0 PLS) ±0.5 MM XX.X (1 PLS) ±0.1 MM X.XX (2 PLS) ±0.03 MM .XXX (3 PLS) ±0.007 MM UNLESS OTHERWISE NOTED ANGLE TOLERANCE ±0°30', UNLESS NOTED Sheet Name: BASE PLANE	Name	Date	SIZE	UNIVERSITY OF LIMERICK OLLSCOIL LUIMNIGH
	Drawn Sara Mikołajczyk	21/03/2024	A4	
	Checked	DO NOT SCALE DRAWING		Title:
	THIRD ANGLE PROJECTION			BASE PLANE
DWG. NO.	Material: 1060 Alloy	Weight:		
REV.	Scale: 1:2	Sheet 8 of 18		

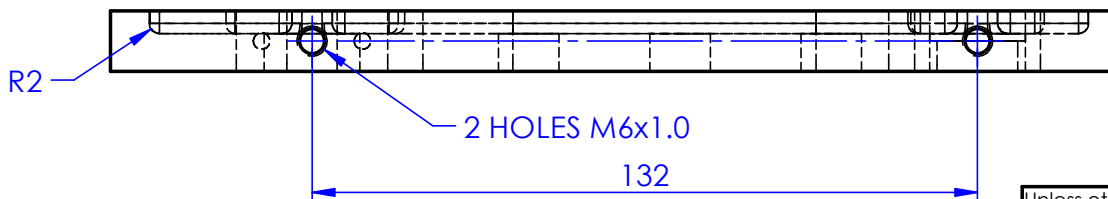
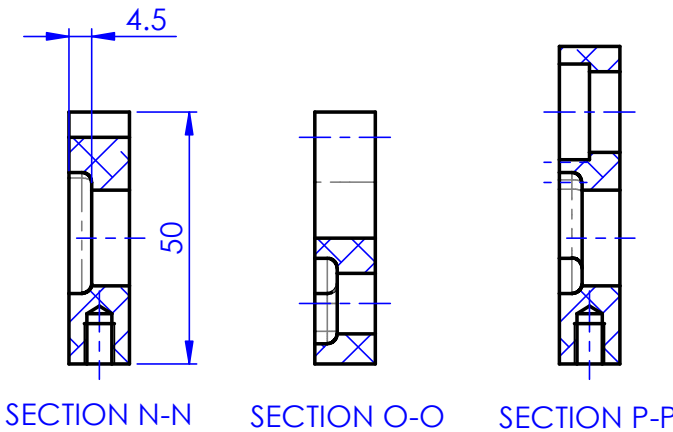
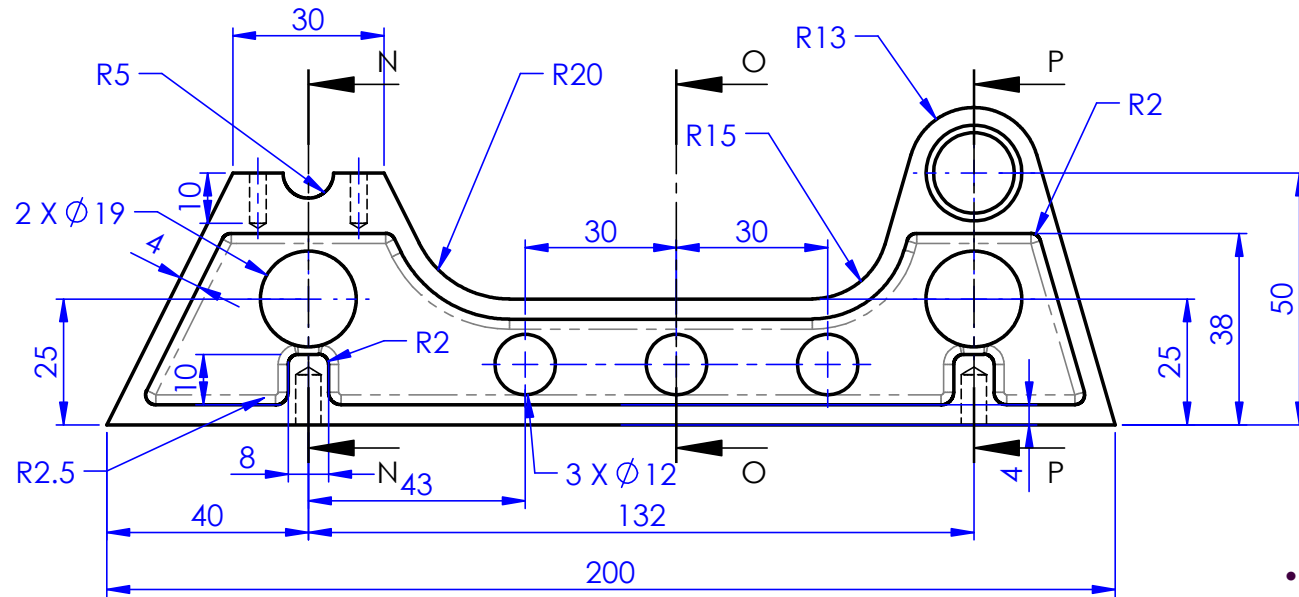
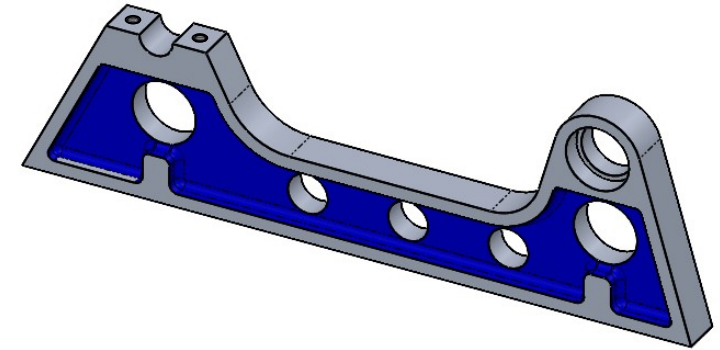
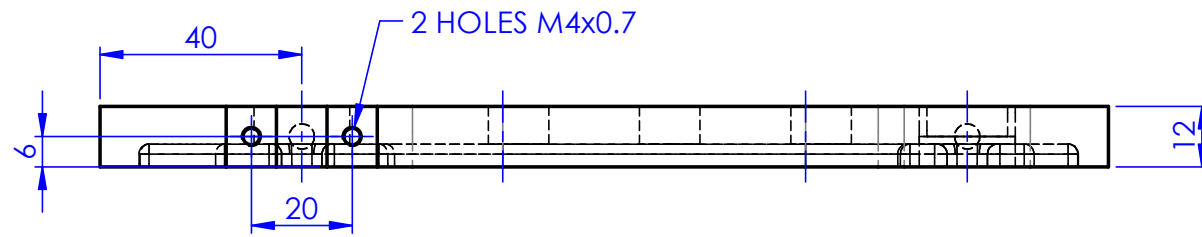

- ALL UNSPECIFIED FILLETS TO BE R2
- FOR THE M 6 AND M4 TAPPED HOLES MAKE THE DRILLED HOLE DEPTH 10 AND THE THREAD DEPTH 8 AS SHOWN IN THE DRAWINGS

Unless otherwise specified dimensions are in millimetres. Tolerances are: XXX (0 PLS) ±0.5 MM XX.X (1 PLS) ±0.1 MM X.XX (2 PLS) ±0.03 MM .XXX (3 PLS) ±0.007 MM UNLESS OTHERWISE NOTED ANGLE TOLERANCE ±0°30', UNLESS NOTED Sheet Name: LEFT SIDE FRAME	Name	Date	SIZE	UNIVERSITY OF LIMERICK OLLSCOIL LUIMNIGH
	Drawn Sara Mikołajczyk	21/03/2024	A4	
	Checked		Title:	
	DO NOT SCALE DRAWING			LEFT SIDE FRAME
THIRD ANGLE PROJECTION		DWG. NO.		Material: 1060 Alloy
		REV.		Weight:
		Scale: 1:1.5		Sheet 9 of 18

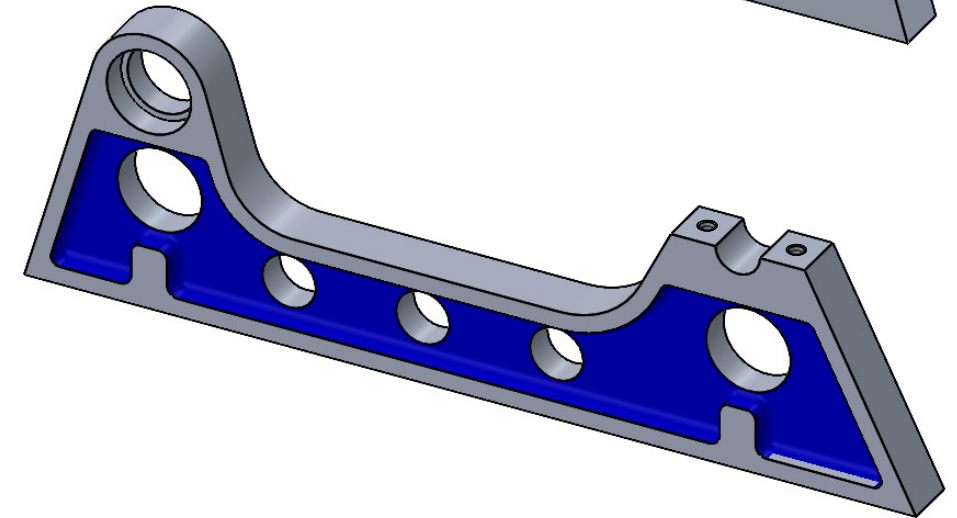
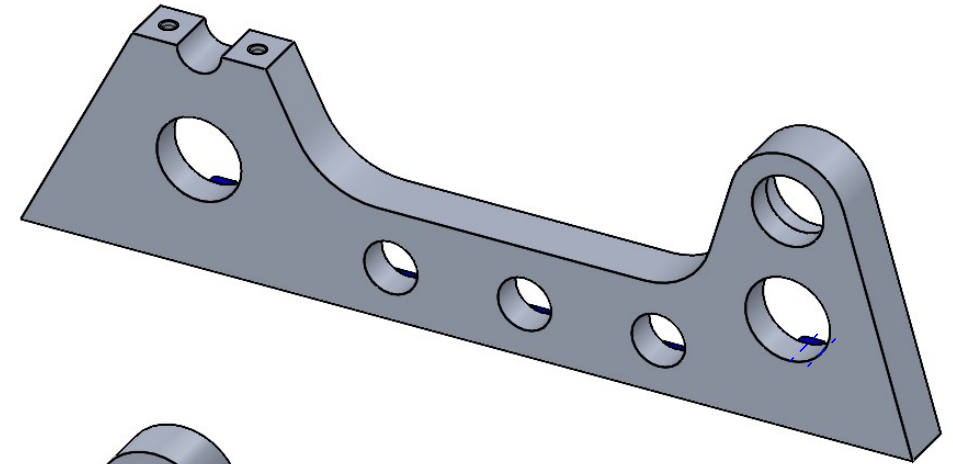
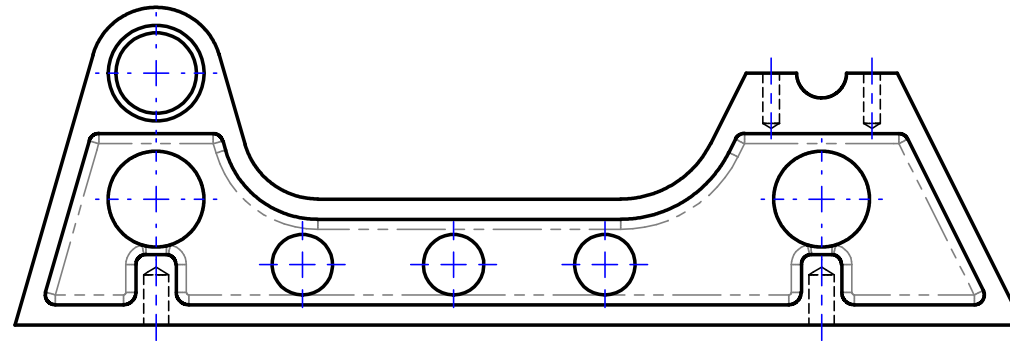
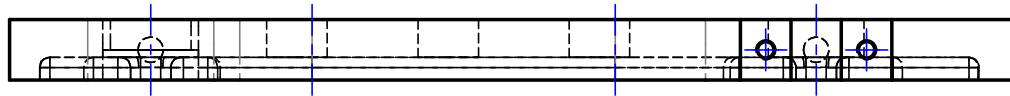

THIS **RIGHT SIDE FRAME** PART IS EXACTLY THE SAME AS THE LEFT SIDE FRAME EXCEPT THAT IT IS THE **OPPOSITE HAND**.

IN SOLIDWORKS TO CREATE A **MIRRORED, DERIVED PART** YOU CLICK THE APPROPRIATE MODEL FACE OR PLANE ABOUT WHICH TO MIRROR THE PART, AND CLICK **INSERT > MIRROR PART**. BECAUSE THE MIRRORED VERSION IS DERIVED FROM THE ORIGINAL VERSION, THE TWO PARTS ALWAYS MATCH

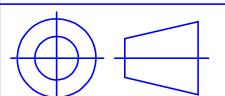
Unless otherwise specified dimensions are in millimetres. Tolerances are: XXX (0 PLS) ±0.5 MM XX.X (1 PLS) ±0.1 MM X.XX (2 PLS) ±0.03 MM .XXX (3 PLS) ±0.007 MM UNLESS OTHERWISE NOTED ANGLE TOLERANCE ±0°30', UNLESS NOTED Sheet Name: RIGHT SIDE FRAME	Name	Date	SIZE A4	 UNIVERSITY OF LIMERICK OLLSCOIL LUIMNIGH
	Drawn Sara Mikołajczyk	21/03/2024		
	Checked		Title: RIGHT SIDE FRAME	
	DO NOT SCALE DRAWING			DWG. NO. REV.
THIRD ANGLE PROJECTION 			Material: 1060 Alloy	Weight:
			Scale: 1:1.5	Sheet 10 of 18

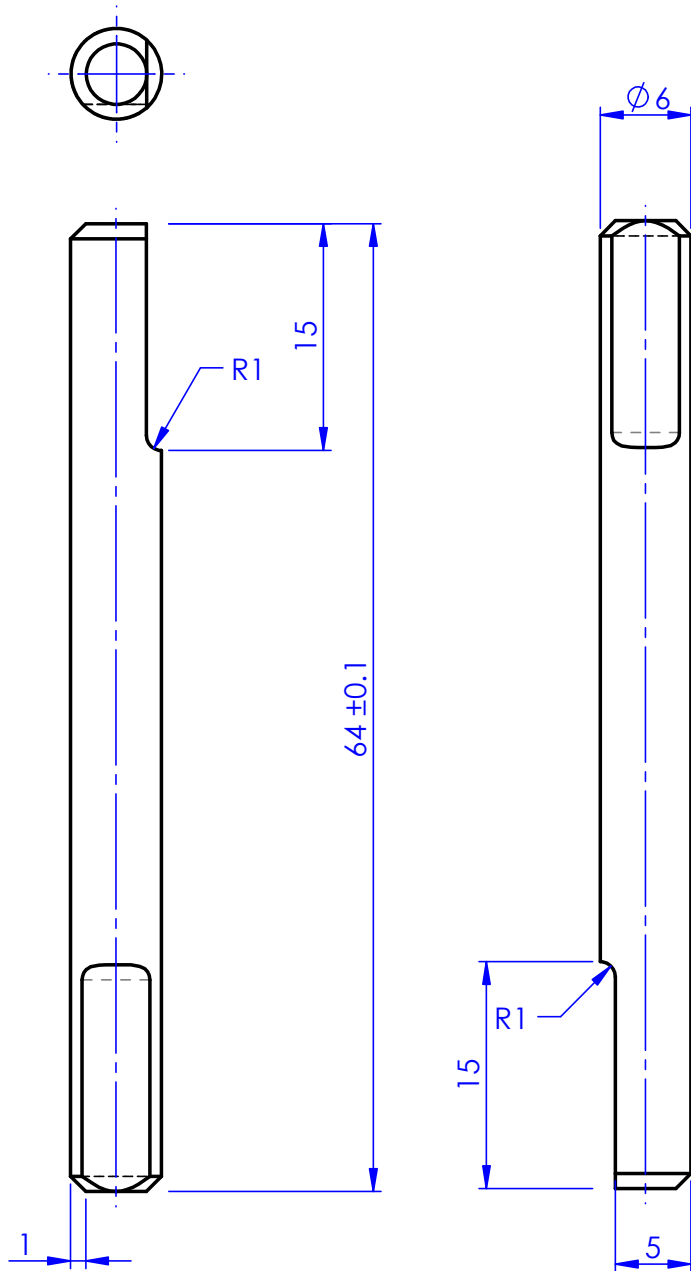

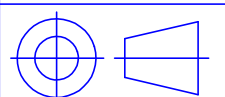
Unless otherwise specified dimensions are in millimetres. Tolerances are: XXX (0 PLS) ± 0.5 MM XX.X (1 PLS) ± 0.1 MM X.XX (2 PLS) ± 0.03 MM .XXX (3 PLS) ± 0.007 MM UNLESS OTHERWISE NOTED ANGLE TOLERANCE $\pm 0^{\circ}30'$, UNLESS NOTED	Name	Date	SIZE	 UNIVERSITY OF LIMERICK OLLSCOIL LUIMNIGH
	Drawn Sara Mikolajczyk	21/03/2024	A4	
Checked	DO NOT SCALE DRAWING		Title: FLYWHEEL SHAFT	
Sheet Name: FLYWHEEL SHAFT	 THIRD ANGLE PROJECTION		DWG. NO.	Material: Plain Carbon Steel
			REV.	Scale: 1:1
				Weight: Sheet 11 of 18

1 X 45° 2 X 45°

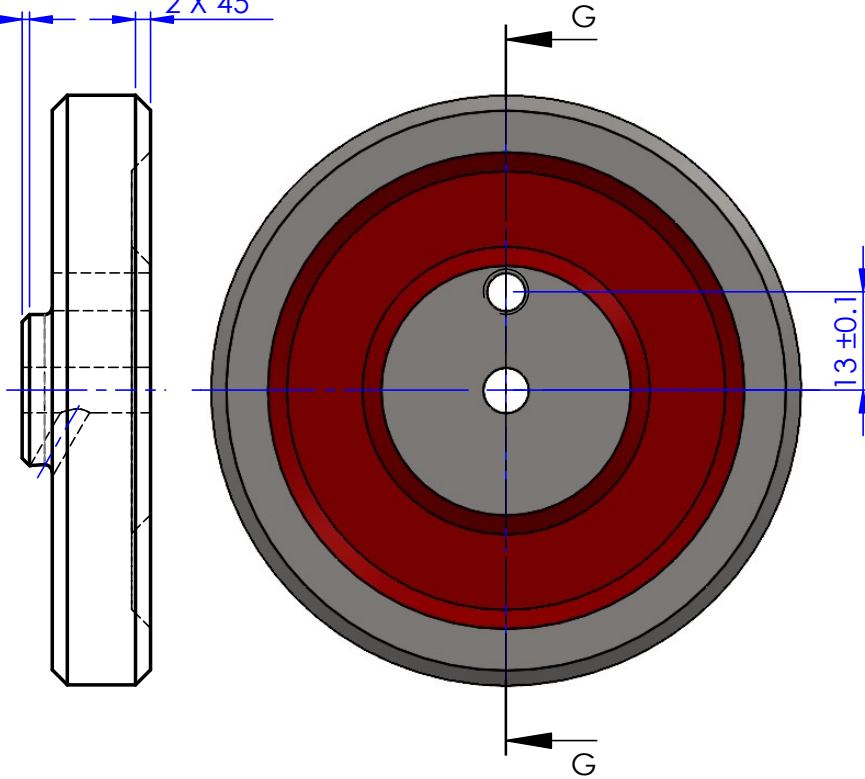

SECTION G-G
SCALE 1 : 1

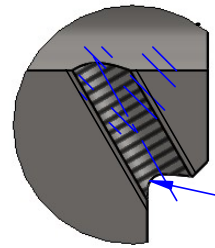
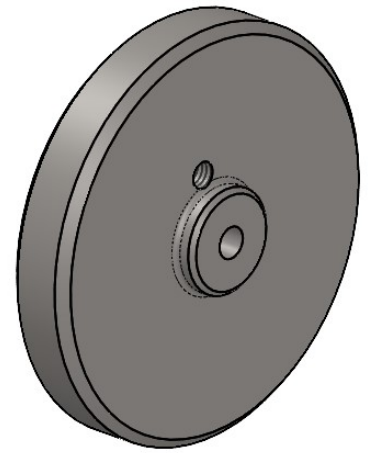
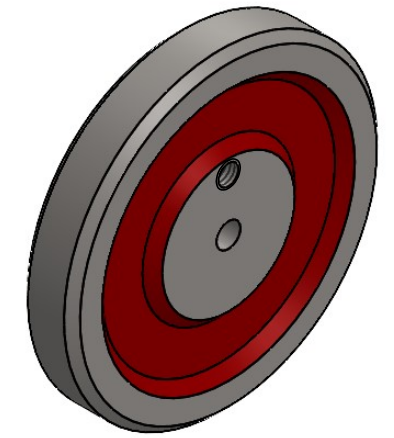
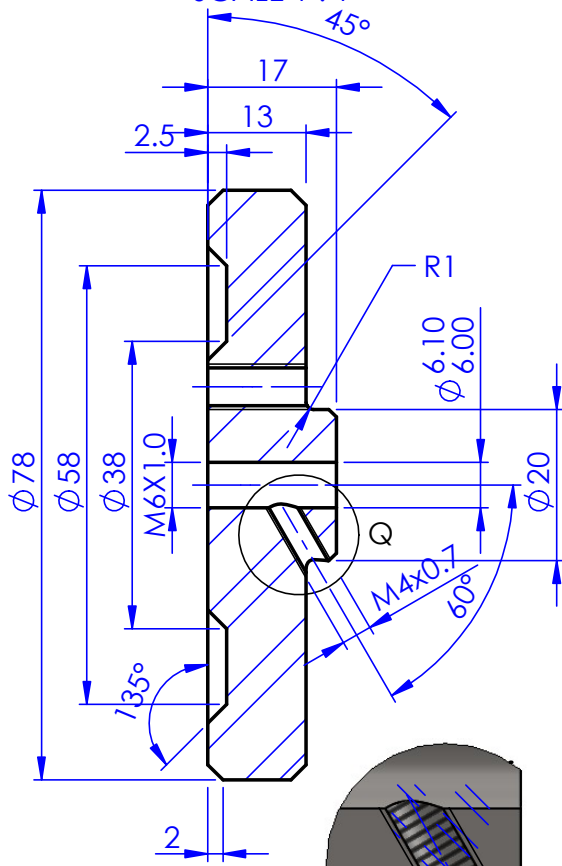

AXIS OF 60° HOLE TO COINCIDE WITH INTERNAL CORNER BEFORE R1 FILLET IS ADDED

DETAIL Q SCALE 2:1

Unless otherwise specified dimensions are in millimetres. Tolerances are: XXX (0 PLS) ±0.5 MM XX.X (1 PLS) ±0.1 MM X.XX (2 PLS) ±0.03 MM .XXX (3 PLS) ±0.007 MM UNLESS OTHERWISE NOTED ANGLE TOLERANCE ±0°30', UNLESS NOTED Sheet Name: FLYWHEEL	Name	Date	SIZE	UNIVERSITY OF LIMERICK OLLSCOIL LUIMNIGH
	Drawn Sara Mikołajczyk	21/03/2024	A4	
	Checked		Title:	
	DO NOT SCALE DRAWING		FLYWHEEL	
THIRD ANGLE PROJECTION		DWG. NO.	Material: Plain Carbon Steel	Weight:
		REV.	Scale: 1:1	Sheet 12 of 18

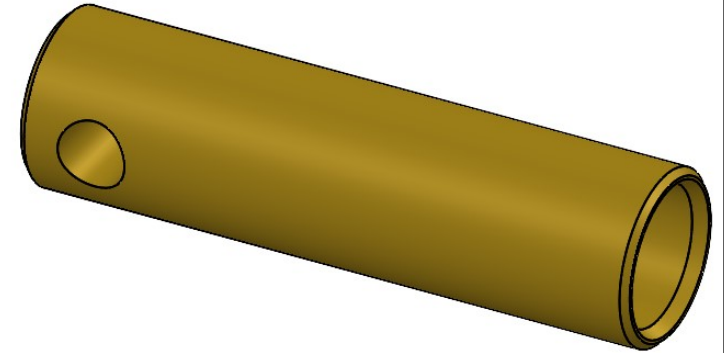
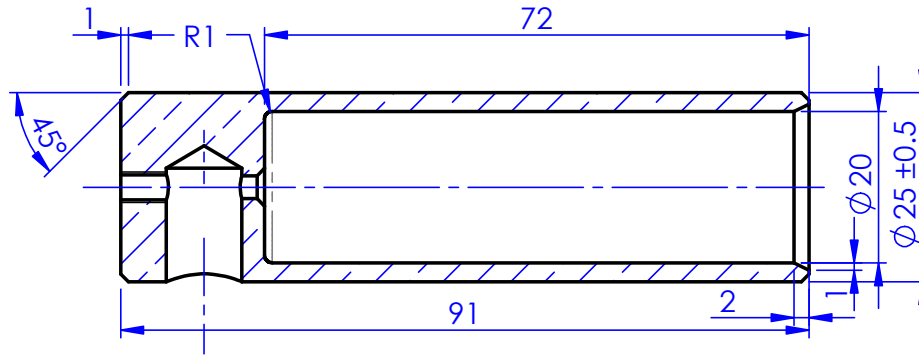

SECTION I-I
SCALE 1 : 1

$\phi 10.018$
 $10.000 \nabla 15$

80

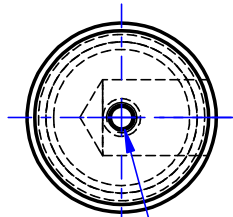

$\phi 3.3$ THRU
M4X0.7 - 6H THRU

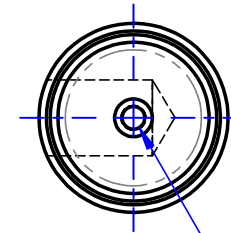
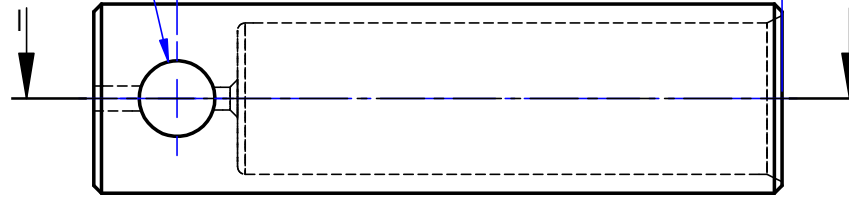

$\phi 3$ THRU $\phi 5 \times 90^\circ$

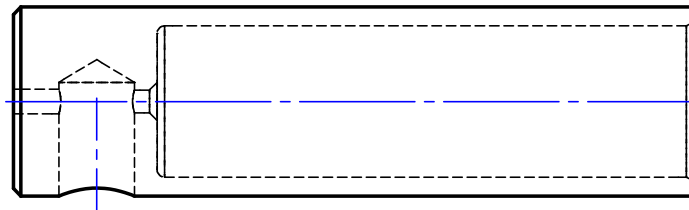

Unless otherwise specified
dimensions are in
millimetres.

Tolerances are:

XXX (0 PLS) ± 0.5 MM
XX.X (1 PLS) ± 0.1 MM
X.XX (2 PLS) ± 0.03 MM
.XXX (3 PLS) ± 0.007 MM
UNLESS OTHERWISE NOTED

ANGLE TOLERANCE $\pm 0^\circ 30'$,
UNLESS NOTED

Sheet Name:

POWER CYLINDER

Name	Date
Drawn Sara Mikołajczyk	21/03/2024
Checked	

DO NOT SCALE DRAWING

THIRD ANGLE PROJECTION

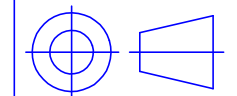

SIZE

A4



Title:

POWER CYLINDER

DWG. NO.

Material: Brass

Weight:

REV.

Scale: 1:1

Sheet 13 of 18

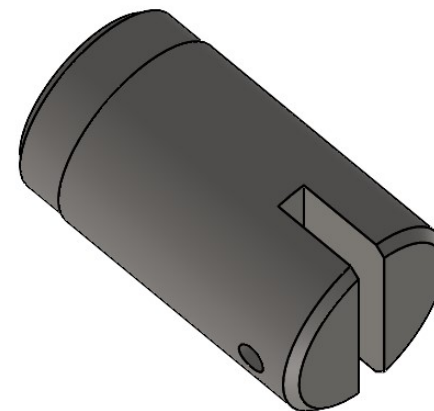
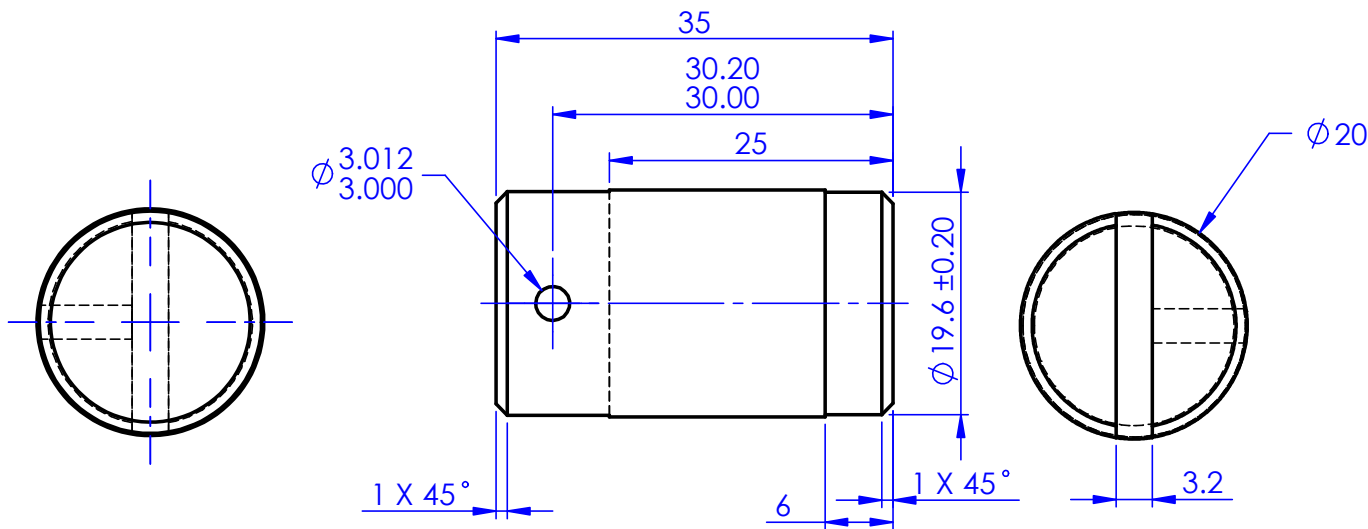
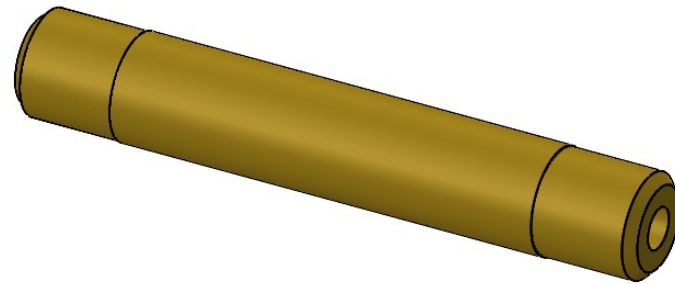
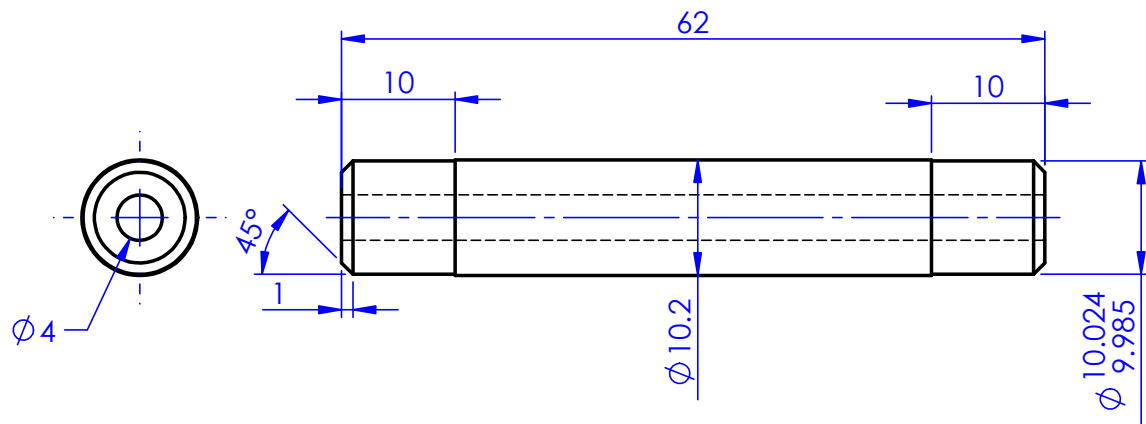

Unless otherwise specified dimensions are in millimetres.

Tolerances are:
 XXX (0 PLS) ±0.5 MM
 XX.X (1 PLS) ±0.1 MM
 X.XX (2 PLS) ±0.03 MM
 .XXX (3 PLS) ±0.007 MM
 UNLESS OTHERWISE NOTED

ANGLE TOLERANCE ±0°30', UNLESS NOTED

Sheet Name:

CROSS CYL & POWER PISTON

Name	Date
Drawn Sara Mikołajczyk	21/03/2024
Checked	

DO NOT SCALE DRAWING

THIRD ANGLE PROJECTION

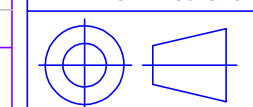

SIZE A4	UNIVERSITY OF LIMERICK OLLSCOIL LUIMNIGH
------------	---

Title:
CROSS CYLINDER SUPPORT PIPE & POWER PISTON

DWG. NO.	Material: Brass	Weight:
REV.	Scale: 1.5:1	Sheet 14 of 18

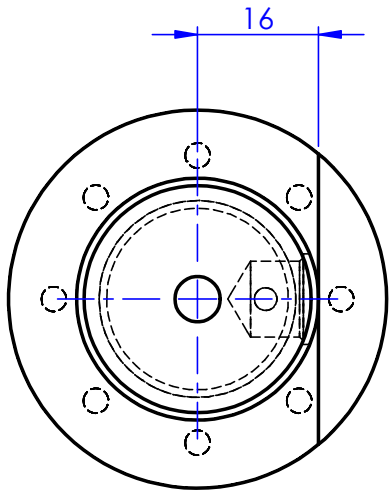

$\varnothing 10.018$
 $10.000 \nabla 9$
 $\varnothing 12 \nabla 2$
 $\surd \varnothing 11 \times 90^\circ$

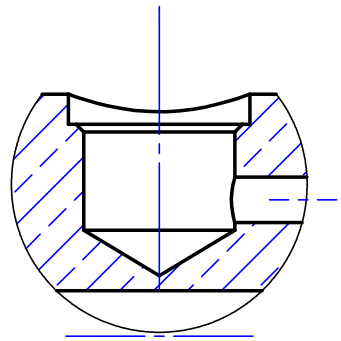
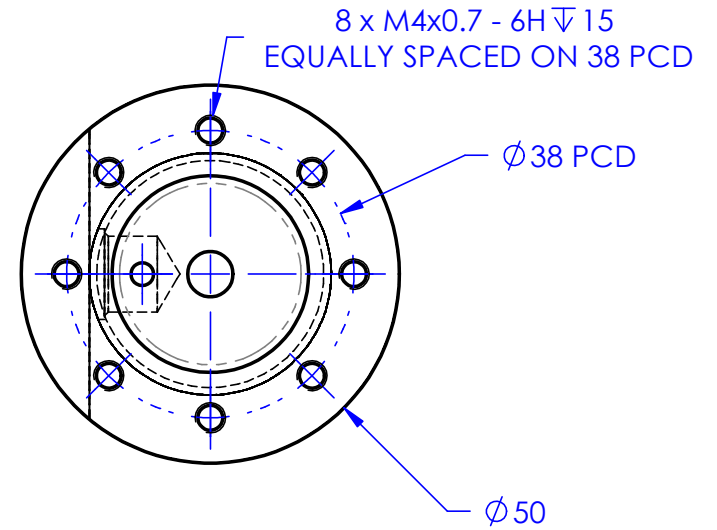
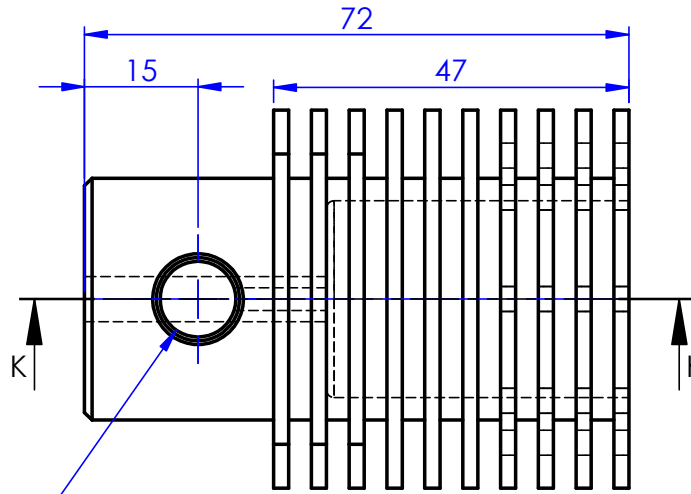

DETAIL L
SCALE 2 : 1

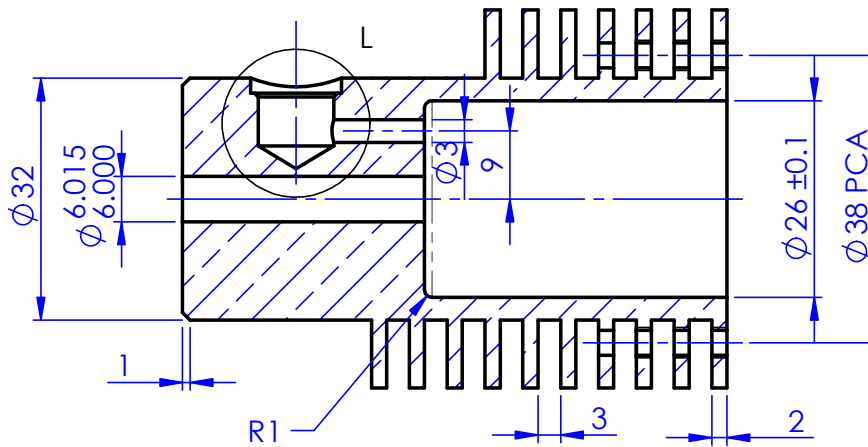

SECTION K-K
SCALE 1 : 1

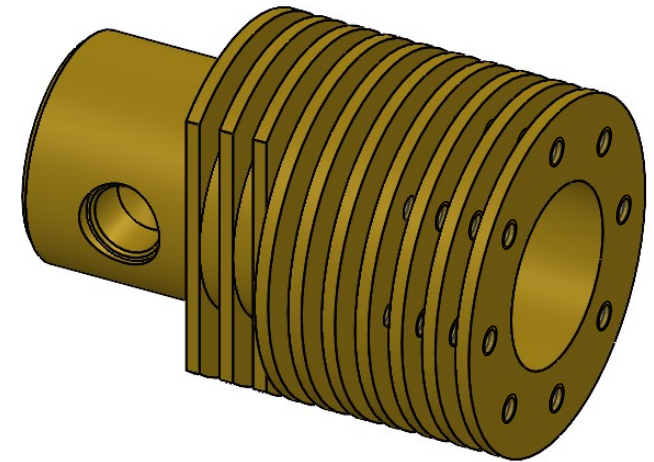

Unless otherwise specified dimensions are in millimetres.

Tolerances are:

XXX (0 PLS) ± 0.5 MM
 XX.X (1 PLS) ± 0.1 MM
 X.XX (2 PLS) ± 0.03 MM
 .XXX (3 PLS) ± 0.007 MM
 UNLESS OTHERWISE NOTED

ANGLE TOLERANCE $\pm 0^\circ 30'$, UNLESS NOTED

Sheet Name:

COLD CYLINDER

Name	Date
Drawn Sara Mikołajczyk	21/03/2024
Checked	

DO NOT SCALE DRAWING

THIRD ANGLE PROJECTION

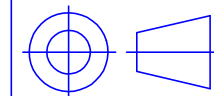

SIZE

A4



Title:

COLD CYLINDER

DWG. NO.

Material: Brass

Weight:

REV.

Scale: 1:2

Sheet 15 of 18

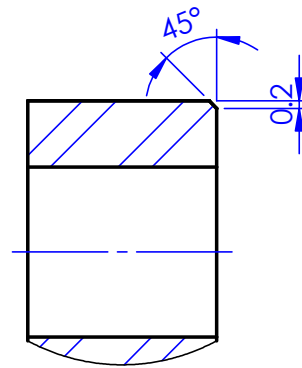

DETAIL B
SCALE 5 : 1

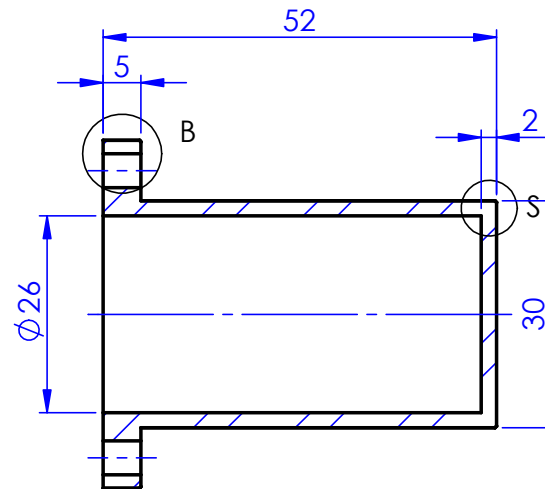
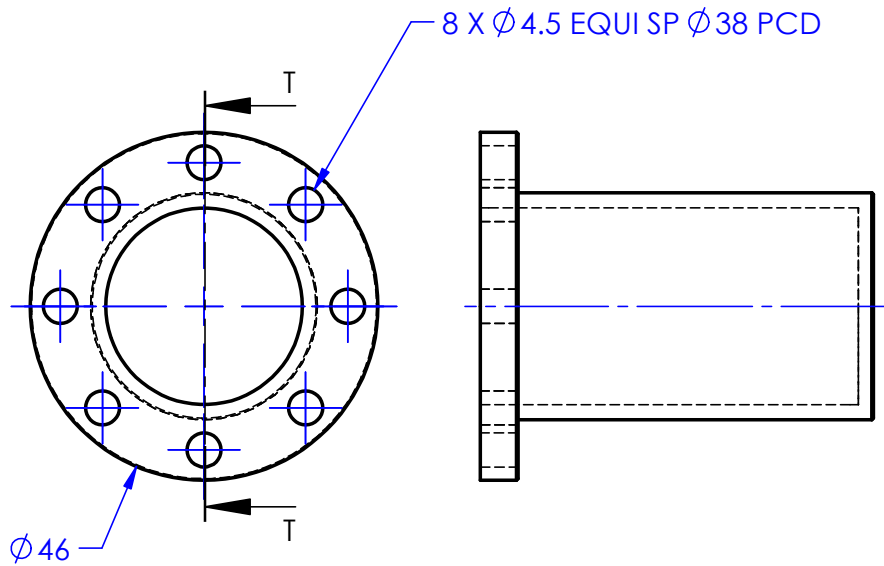
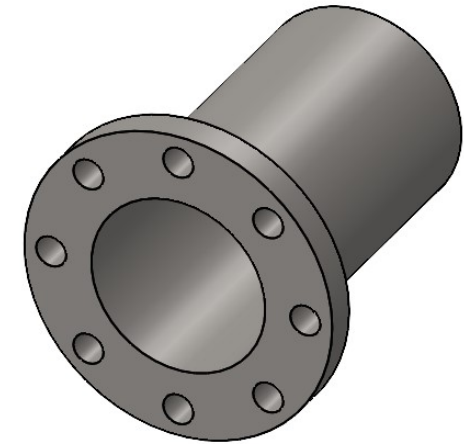

SECTION T-T

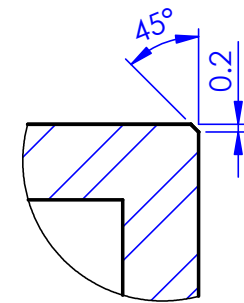

DETAIL S
SCALE 5 : 1

Unless otherwise specified dimensions are in millimetres. Tolerances are: XXX (0 PLS) ±0.5 MM XX.X (1 PLS) ±0.1 MM X.XX (2 PLS) ±0.03 MM .XXX (3 PLS) ±0.007 MM UNLESS OTHERWISE NOTED ANGLE TOLERANCE ±0°30', UNLESS NOTED Sheet Name: HOT CYLINDER	Name	Date	SIZE	 UNIVERSITY OF LIMERICK OLLSCOIL LUIMNIGH
	Drawn Sara Mikołajczyk	21/03/2024	A4	
	Checked	DO NOT SCALE DRAWING		Title:
	THIRD ANGLE PROJECTION			HOT CYLINDER
DWG. NO.	Material: Plain Carbon Steel	Weight:		
REV.	Scale: 1:1	Sheet 16 of 18		

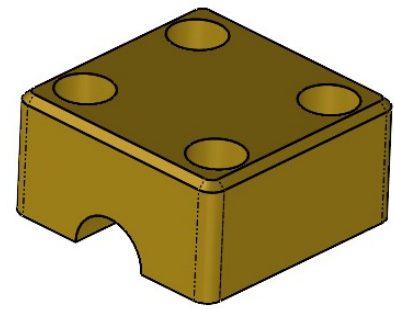
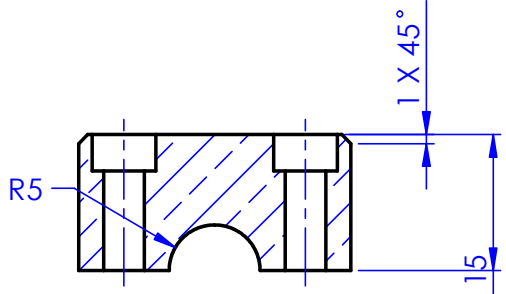
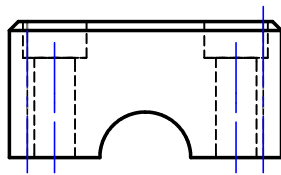
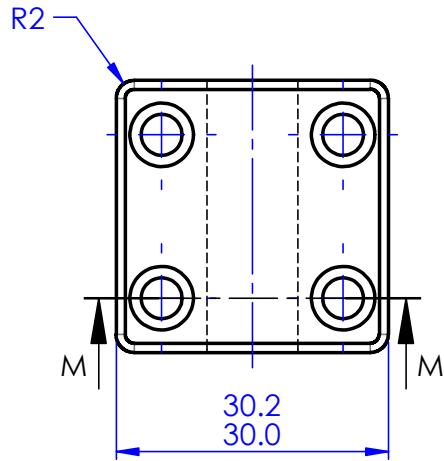

COUNTERBORES SIZED TO SUIT M4 SOCKET HEAD CAP SCREW

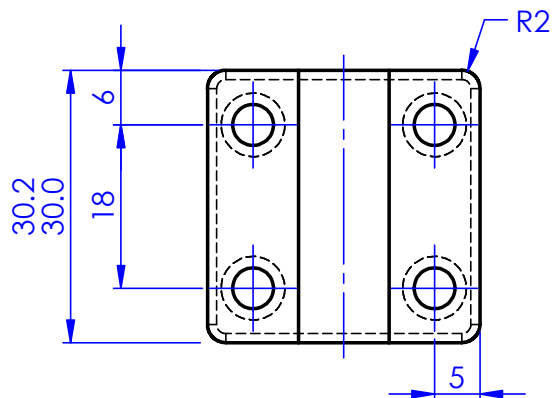

SECTION M-M
SCALE 1.2:1

Unless otherwise specified dimensions are in millimetres. Tolerances are: XXX (0 PLS) ±0.5 MM XX.X (1 PLS) ±0.1 MM X.XX (2 PLS) ±0.03 MM .XXX (3 PLS) ±0.007 MM UNLESS OTHERWISE NOTED ANGLE TOLERANCE ±0°30', UNLESS NOTED	Name	Date	SIZE A4	
	Drawn Sara Mikolajczyk	21/03/2024	Checked	
Sheet Name: CROSS CYLINDER SUPPORT	DO NOT SCALE DRAWING			
	DWG. NO.	Material: Brass	Weight:	
	REV.	Scale: 1.2:1	Sheet 17 of 18	

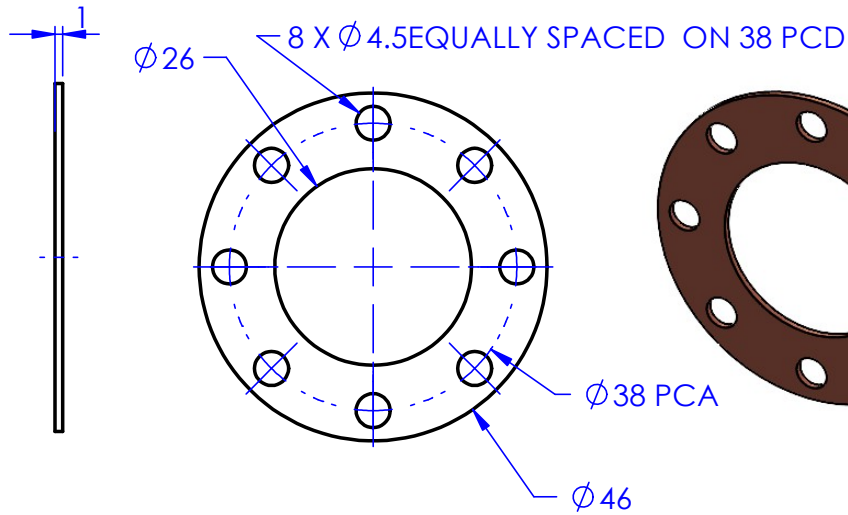

GASKET - MATERIAL: COPPER
SCALE 1:1

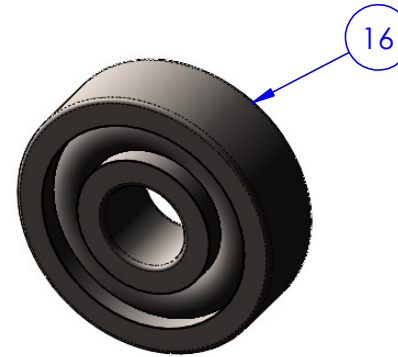
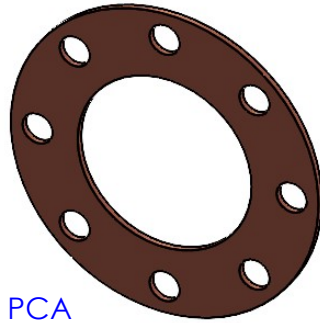

INSTRUMENT PRECISION
BALL BEARING 20619 2 OFF

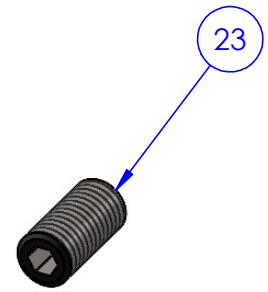

M4 X 10 SOCKET GRUB
SCREW CONE POINT
2 OFF

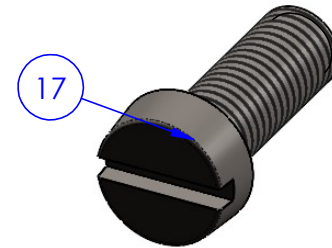

M6 X 16 SLOTTED CHEESE
HEAD SCREW
2 OFF

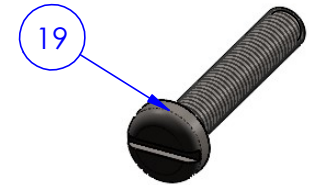

M3 X 16 SLOTTED PAN
HEAD SCREW

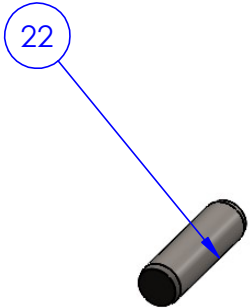

M4 X 16 SOCKET HEAD
CAP SCREW
4 OFF

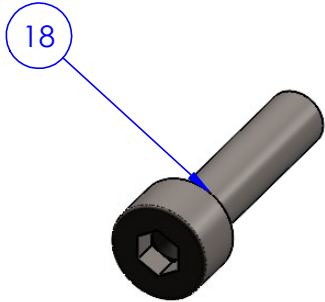

M4 X 16 SOCKET HEAD
CAP SCREW
4 OFF

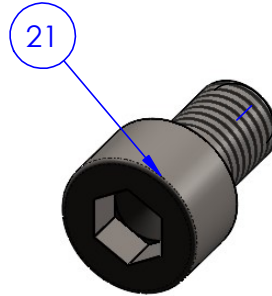

M6 X 10 SOCKET HEAD
CAP SCREW
4 OFF

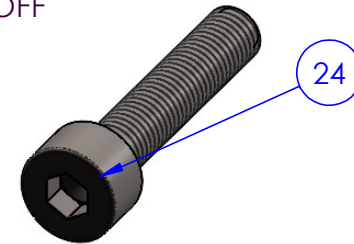

M4 X 20 SOCKET HEAD
CAP SCREW
8 OFF

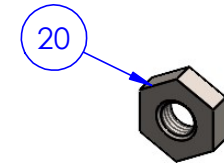

M3 HEXAGONAL
THIN NUT

Unless otherwise specified dimensions are in millimetres. Tolerances are: XXX (0 PLS) ± 0.5 MM XX.X (1 PLS) ± 0.1 MM X.XX (2 PLS) ± 0.03 MM .XXX (3 PLS) ± 0.007 MM UNLESS OTHERWISE NOTED ANGLE TOLERANCE $\pm 0^{\circ}30'$, UNLESS NOTED Sheet Name: GASKET AND TOOLBOX PARTS	Name	Date	SIZE	UNIVERSITY OF LIMERICK OLLSCOIL LUIMNIGH
	Drawn Sara Mikolajczyk	21/03/2024	A4	
	Checked	DO NOT SCALE DRAWING		Title:
	THIRD ANGLE PROJECTION			GASKET AND TOOLBOX PARTS
DWG. NO.		Material: Copper	Weight:	
REV.		Scale: 2:1	Sheet 18 of 18	